

CALIFORNIA VANPOOL AUTHORITY

Board of Directors

1340 North Drive * Hanford, California 93230
(559) 852-2711

Meeting Date: May 10, 2018

Time: 10:00 AM

Place: Kings County Association of Governments
CalVans office at 1340 North Drive, Hanford, CA 93230

This Meeting may also be attended at the following locations:

- Association of Monterey Bay Area Governments, 24580 Silver Cloud Court Monterey, CA 93940
- Fresno Council of Governments, Chicano Youth Center, 1515 E Divisadero, Fresno CA 93721
- Imperial County Transportation Commission, 1405 N Imperial Ave, Suite 1, El Centro, CA 92243 and 128 W. 5th Street, Holtville, CA 92250
- Kern Council of Governments, Conference 1401 19th Street, Board Room, Bakersfield, CA 93301
- Madera County Transportation Commission, Citizens Business Bank, Room 101, 2001 Howard Road, Madera, CA 93637
- Merced County Association of Governments, Conference Room, 369 West 18th Street, Merced, CA 95340
- Riverside County Transportation Commission, Marriott Wardman Park, 2660 Woodley Rd NW, Washington, DC 20008
- San Joaquin Council of Governments, 555 E. Weber Avenue, Stockton, CA 95202 and San Joaquin County Administration Building, 44 N. San Joaquin Street, Room 637, Stockton, CA 95202
- Santa Barbara County Association of Governments, 1644 Oak Street, Solvang CA 93463
- Tulare County Association of Governments, Conference Room, 210 N Church St., Suite B, Visalia, CA 93291 and Visalia Government Plaza Main Lobby, 5953 S Moony Blvd. Visalia, CA 93277.
- Ventura County Transportation Commission, Conference Room, 950 County Square Drive, Suite 108, Ventura, CA 9300
- **San Joaquin Valley Policy Conference at the Double Tree Inn in Modesto, 1150 Ninth Street, Modesto, CA on the 12th floor in the EMC Boardroom.**

The call in number for this meeting is 1-866-244-8528, Password 574681

Please note that the Brown Act requires that Board members calling in do so from one of the locations noted above. Please contact Ronald Hughes the Executive Director at least 72 hours before the meeting date and time if you plan on calling in from another location.

A person with a qualifying disability under the Americans with Disabilities Act of 1990 may request the Authority to provide a disability-related modification or accommodation in order to participate in any public meeting of the Authority. Such assistance includes appropriate alternative formats for the agendas and agenda packets used for any public meetings of the Authority. Requests for such assistance and for agendas and agenda packets shall be made in person, by telephone, facsimile, or written correspondence to Ron Hughes, at the office of the California Vanpool Authority, at least 48 hours before a public Authority meeting.

A G E N D A

<u>Item #</u>	<u>Description</u>	<u>Action</u>
1.	CALL TO ORDER Roll Call – Clerk of the Board	
2.	PUBLIC COMMENT (Unscheduled Appearances) The public may address the committee on any item relevant to the authority. To comment on an agenda item, speakers should notify the staff member at the meeting location, when the agenda item is announced. The staff member will indicate whether speakers are to make their comments before or after any staff comment or report. Public comment shall precede discussion of the item by the committee. Comments by individuals and entities will be limited to five minutes or as may be reasonable as determined by the conducting officer.	
3.	Consent Items A. Minutes of March 8, 2018	Action
4.	Authorize signing of Resolution 2018-01	Action
5.	Adjournment – Next Board meeting – June 14th	

Attachments:

Item Page Description

- A. Board minutes for March 8, 2018
- B. Resolution 2018-01

STAFF REPORT

3. Consent Items

A. Minutes of March 8, 2018

The attached minutes from the last meeting are ready for approval, pending any changes from the members.

4. Authorize signing of Resolution 2018-01

Staff received notification that CalVans was awarded the \$6 million grant that it recently applied for. The grant targets farmworker vanpools in the San Joaquin Valley, with the ability to provide vans to areas outside the valley. The grant also provides for marketing efforts within the San Joaquin Valley towards those farmworkers who may not have heard about the CalVans program. This effort will include community outreach meeting where other civic organizations are invited to participate. This approach generally attracts a larger group to the meetings.

The 154 vehicles being funded by the grant have been ordered and will begin arriving in July. The vehicles are 15-passenger vans that will have an XLhybrid package installed in place of the spare tire. The XLhybrid package will operate like an early model Prius, storing energy as the van brakes to be used on acceleration. Fuel saving will average around 25% for those vehicles equipped with the package.

Staff was going to hold off and approve the resolution at the meeting in June but was informed that the grant had to be executed by the end of this month or the funds would lapse. For that reason Staff is asking for approval of the attached resolution, authorizing the Executive Director to sign the final grant agreement. A draft is being prepared and was not available at the time I prepared this agenda. It will be available early next week, at which time I will send it out.

The following page explains the XLhybrid package.



Simple. Smart. Sustainable.



XL3[®] Hybrid Electric Solution

➤ Provides a 25% increase in miles driven per gallon*

XL Hybrids, the leader in connected fleet electrification solutions, gives commercial van and shuttle fleets a simple solution for lowering operating costs and meeting sustainability goals. Our revolutionary hybrid technology seamlessly installs onto OEM powertrains and delivers a 25% increase in miles per gallon*. Plus, ordering is easy and now financing options are available.

Big Savings

On fuel – 25% increase in miles per gallon*, so drivers can go longer between fill-ups.

On emissions – helps your fleet go green and meet sustainability goals by reducing CO2 emissions.

On price – the XL3 Hybrid Electric Drive System is the lowest-priced, highest quality hybrid electric solution available today.

Superior Driveability

Vehicles equipped with the XL3 hybrid system drive just like the other units in your fleet – no driver training needed. There’s minimal impact on your maintenance schedule and fleet operations. With millions of fleet miles, XL Hybrids vehicles have a proven track record of 99.9+ % vehicle up-time.

Positive Payback

Fleets get an attractive payback even without government incentives. Plus, you’ll see immediate monthly savings on fuel costs.

Financing Options

Save money from Month 1 with long-term financing – rates as low as 5.85%.**

➤ **For Sales Call: 617.718.0329**
or email sales@xlhybrids.com

xlhybrids.com | Simple. Smart. Sustainable.



Quick Install
6 hrs.

Easy integration as a new vehicle upfit or as a retrofit.

CARGO VANS & PASSENGER WAGONS AVAILABILITY

- Chevy Express and GMC Savanna 2500/3500 Vans (4.8L and 6.0L engines)

*Actual MPG may vary.
**Subject to change based on Treasury rates. Actual rates may vary based on customer credit.

XL3[®] Hybrid Electric Drive System

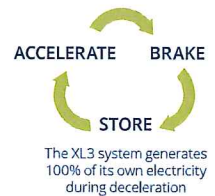
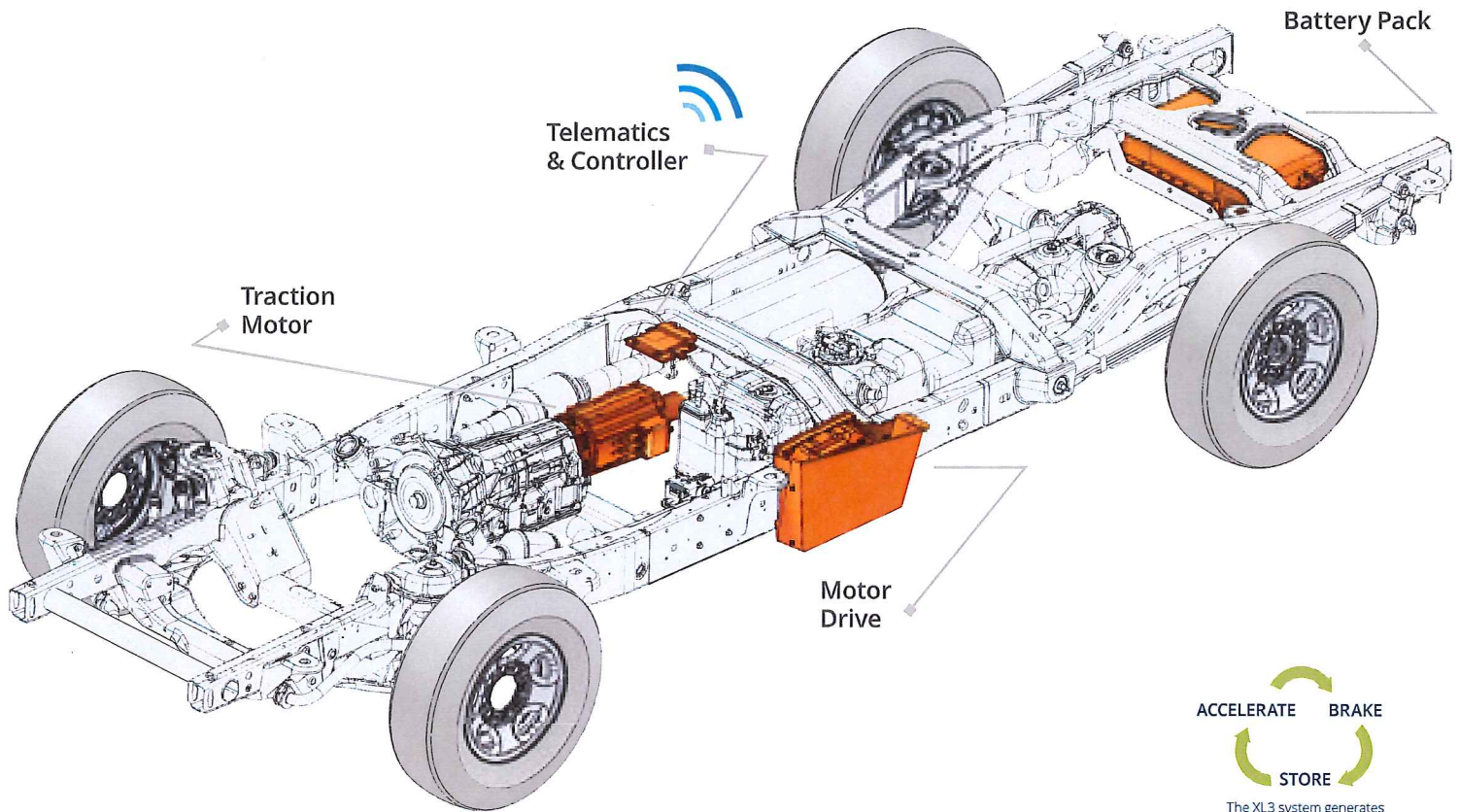

XL Hybrids has pioneered a hybrid electric powertrain that is revolutionary in its simplicity. Our powertrain technology is charge sustaining, which eliminates the need for plugs, return-to-base fueling, and added operating and maintenance costs. Our hybrid system saves fuel through regenerative braking, a process by which the electric motor helps slow the vehicle during braking to charge the hybrid battery. Then as the driver accelerates, the hybrid battery releases the stored energy to the electric motor, helping to propel the vehicle.

Hybrid Powertrain

System Voltage
Lithium-Ion Battery
Hybrid System Torque (peak)
Hybrid System Weight
Electronic Speed Governor
Hybrid Component Warranty

Specifications

259V
1.8 kWh
220 lb-ft
350 lbs
Up to 75 MPH
3-Year / 75,000 Miles

2017_11_01_US